

EHS-EC15 Elliptical Horn Speaker, 15W



Features

- ▶ High quality horn speaker designed with elliptical cabinet. provides uniform ambience of sound high sound output in a wider area.
- ▶ 100V line operation with power taps 15W, 7.5W and 3.75W.
- ▶ Ideal for railways and metro station, parking lots, schools, corridors etc.
- ▶ Provided with U type strong metal bracket for rigid mounting.

TECHNICAL SPECIFICATIONS

Rated Power/ Max. Power	15W / 23W
Power Tappings	15W - 7.5W - 3.75W
SPL at 1W (at 1Khz,1m)	105 dB
Impedance	667/1333/2666 ohm
Frequency range (-10 dB)	500 Hz ~3.5KHz
Dimensions	220(L)x162(W)x235(H)mm
Mounting Type	U shape metal bracket
Weight	1.44 Kg
Material	ABS
Color	White

CIRCUIT DIAGRAM

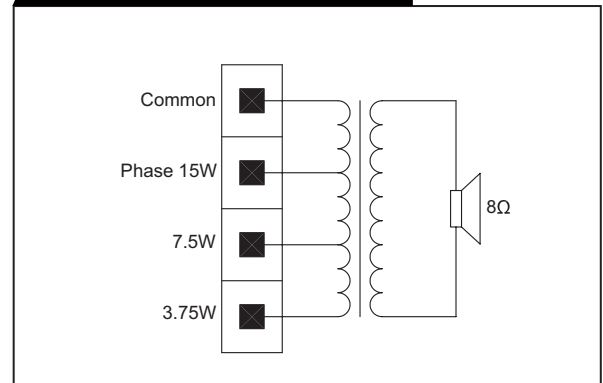

DIMENSION

THREE-VIEW DIAGRAM

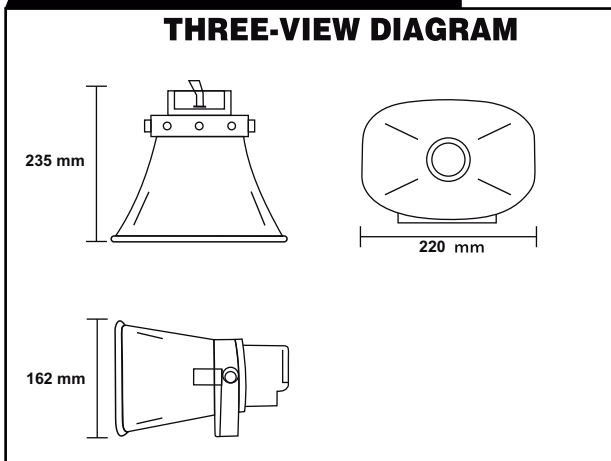

FREQUENCY RESPONSE

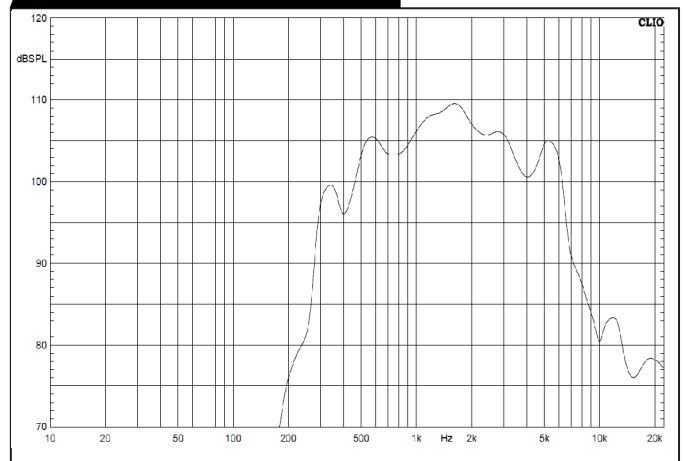

Products are continually improved. All specifications are subject to change without prior notice | For more information, contact info@economicaudio.in

Economic Audio India Pvt Ltd

T-4/31, Phase-1, Mangolpuri Industrial Area, Delhi- 110083, India

Tel: +91 9811656565

Email: info@economicaudio.in

Website: www.economicaudio.in